

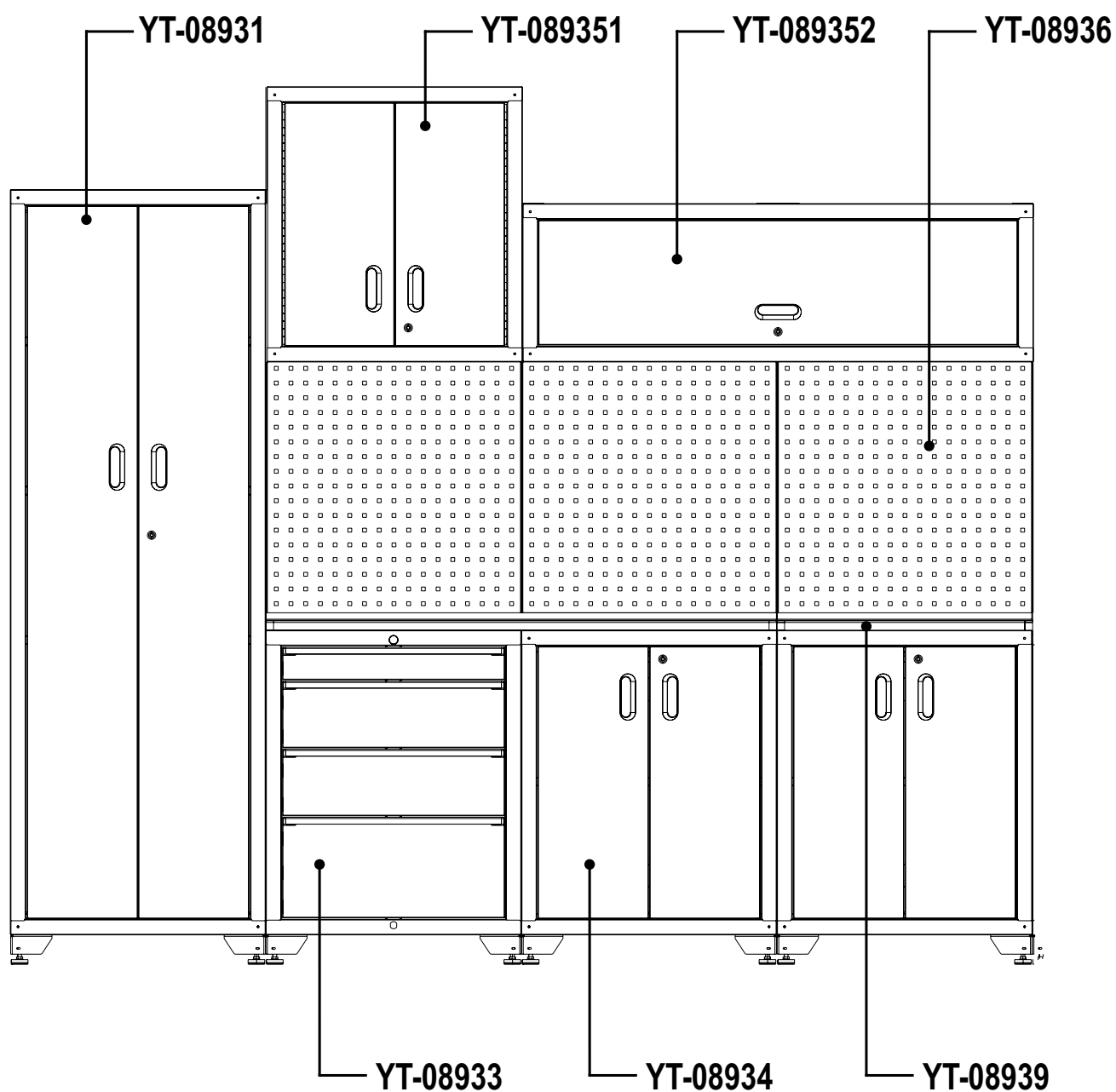







YATO

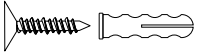
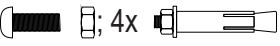

Nr katalogowy Product Number	Nazwa produktu Product Name	Wymiary Dimensions	Aksesoria Accessories
YT-08931	Szafka warsztatowa wysoka High workshop cabinet	600 x 2000 x 457 [mm]	16x M5x15 
YT-08933	Szafka warsztatowa Workshop cabinet	660 x 863 x 457 [mm]	16x M5x15 
YT-08934	Szafka warsztatowa Workshop cabinet	660 x 863 x 457 [mm]	16x M5x15 
YT-08936	Panel perforowany Hook panel	660 x 700 x 20 [mm]	21x 
YT-08939	Błat roboczy Worktop	1980 x 25 x 457 [mm]	
YT-089351	Szafka podwieszana Wall cabinet	660 x 305 x 712 [mm]	4x M8x18  ; 4x 
YT-089352	Szafka podwieszana Wall cabinet	1320 x 305 x 410 [mm]	8x M8x18  ; 8x 

[mm]

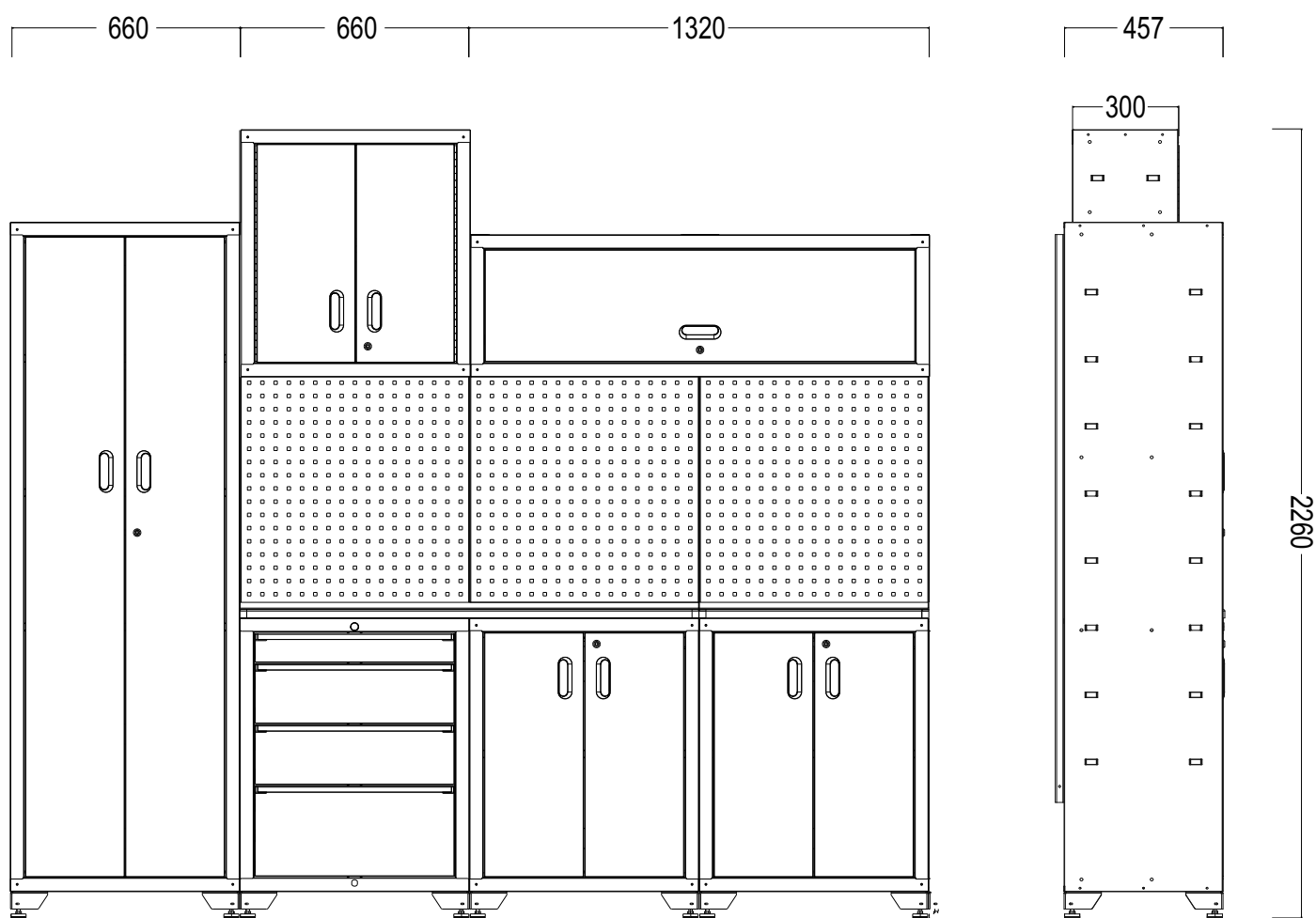

Krok 1: Przymocować regulowaną podstawę z gwintem do spodu, wyrównać zewnętrzną stronę z płytą bazową i zamontować pozostałe trzy narożniki w ten sam sposób.
Step 1: Fix the threaded adjustable base to the bottom, align the outer side with the base plate, and install the other three corners in the same way.

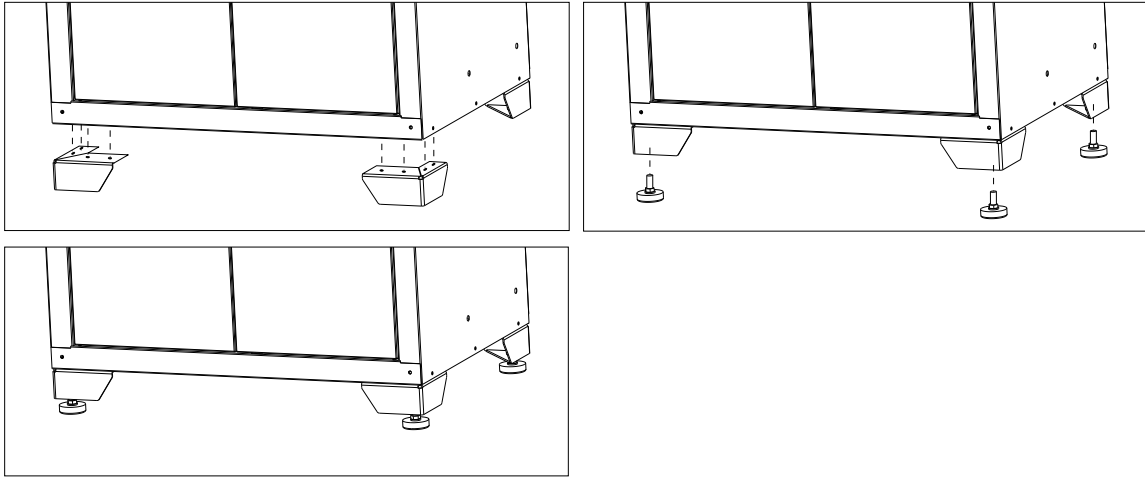

Krok 2: Ustawić szafki wiszące w odpowiednich miejscach, jedna po drugiej.
Step 2: Place the wall cabinet units in appropriate positions one by one.

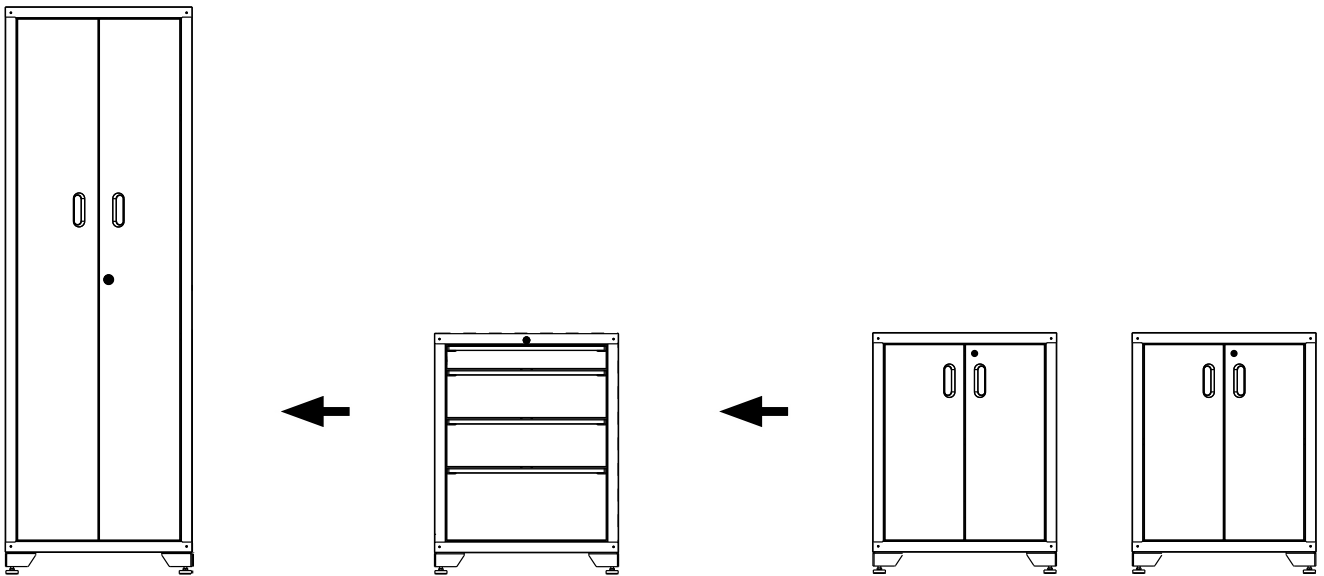

Krok 3: Położyć blat na dolnej szafce.
Step 3: Put the tabletop on top of the bottom cabinet.

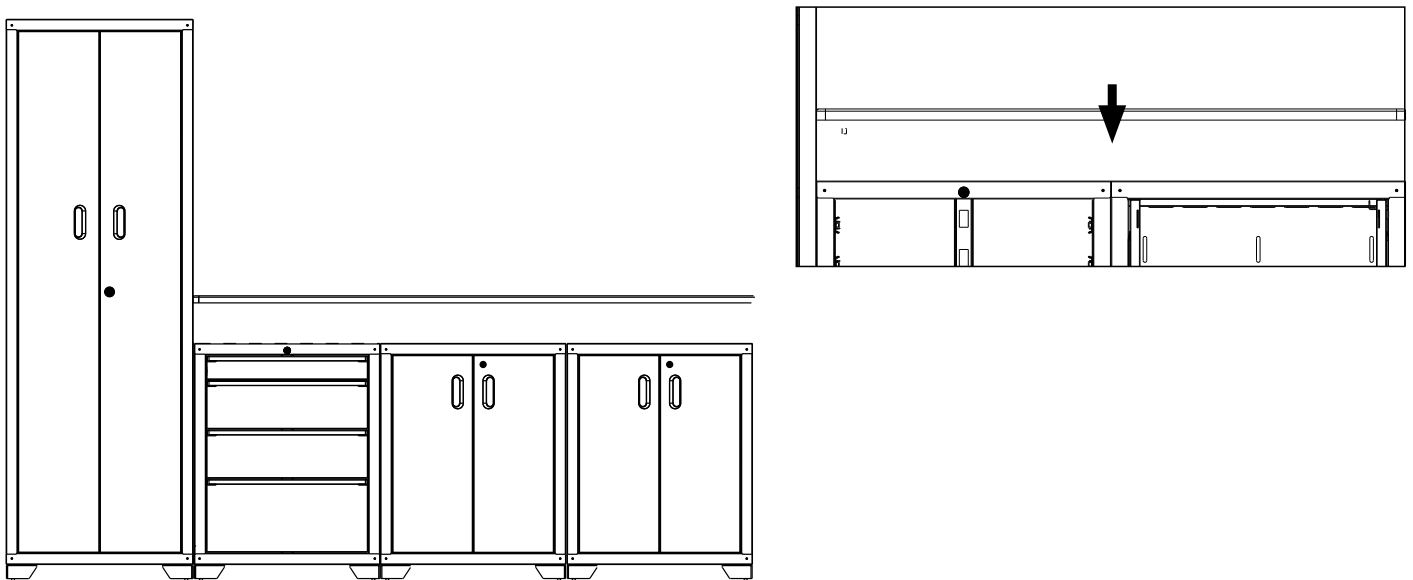

Krok 4: Przymocować ażurową płytę wiszącą do ściany za pomocą kołków rozporowych.
Step 4: Fix the mesh hanging plate on the wall with expansion screws.

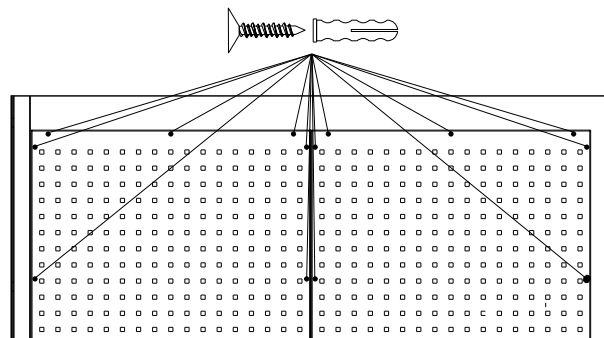
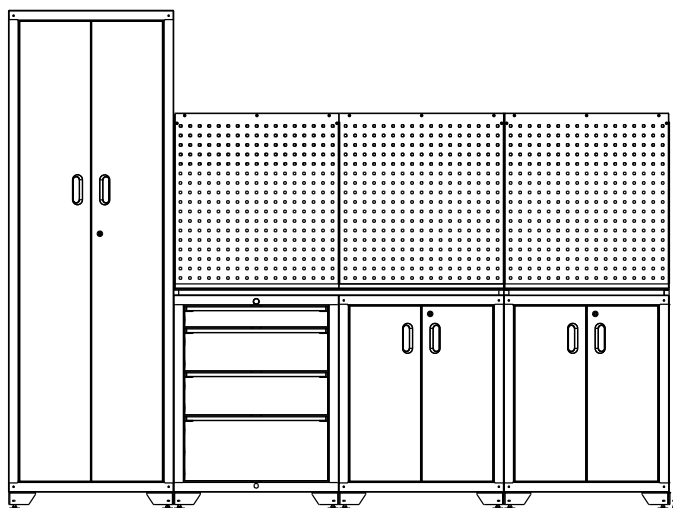

Krok 5: Przymocować szafkę wiszącą do ściany za pomocą śrub rozporowych.
Step 5: Secure the wall cabinet to the wall with expansion bolts.

